

## N-Channel Enhancement Vertical D-MOS Transistor

### Features

- High-speed switching
- No secondary breakdown

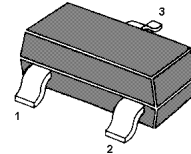

1. Gate 2. Source 3. Drain  
SOT-23 Plastic Package

### Applications

- Thin and thick film circuits
- General purpose fast switching applications

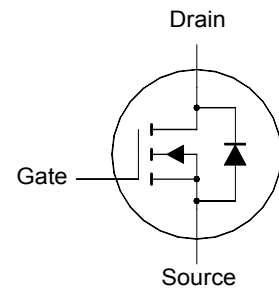

### Absolute Maximum Ratings ( $T_a = 25\text{ }^\circ\text{C}$ unless otherwise specified)

Parameter	Symbol	Value	Unit
Drain-Source Voltage	$V_{DS}$	50	V
Gate-Source Voltage (open drain)	$V_{GSO}$	$\pm 20$	V
Drain Current	$I_D$	100	mA
Peak Drain Current	$I_{DM}$	300	mA
Total Power Dissipation	$P_{tot}^{1)}$	300	mW
	$P_{tot}^{2)}$	250	mW
Junction Temperature	$T_j$	150	$^\circ\text{C}$
Storage Temperature Range	$T_s$	- 65 to + 150	$^\circ\text{C}$

### Thermal Characteristics

Parameter	Symbol	Value	Unit
Thermal Resistance from Junction to Ambient	$R_{\theta JA}$	430 <sup>1)</sup>	K/W
	$R_{\theta JA}$	500 <sup>2)</sup>	K/W

1) Device mounted on a ceramic substrate 10 X 8 X 0.7 mm.

2) Device mounted on a printed-circuit board.

**Characteristics at  $T_a = 25\text{ }^\circ\text{C}$  unless otherwise specified**

Parameter	Symbol	Min.	Max.	Unit
Drain-Source Breakdown Voltage at $I_D = 10\text{ }\mu\text{A}$	$V_{(BR)DSS}$	50	-	V
Drain-Source Leakage Current at $V_{DS} = 40\text{ V}$	$I_{DSS}$	-	1	$\mu\text{A}$
Gate-Source Leakage Current at $V_{GS} = \pm 20\text{ V}$	$I_{GSS}$	-	$\pm 100$	nA
Gate-Source Threshold Voltage at $V_{DS} = V_{GS}$ , $I_D = 1\text{ mA}$	$V_{GS(th)}$	0.4	1.8	V
Drain-Source On-State Resistance at $V_{GS} = 10\text{ V}$ , $I_D = 100\text{ mA}$ at $V_{GS} = 5\text{ V}$ , $I_D = 100\text{ mA}$ at $V_{GS} = 2.5\text{ V}$ , $I_D = 10\text{ mA}$	$R_{DS(on)}$	- - -	15 20 30	$\Omega$
Forward Transfer Admittance at $V_{DS} = 10\text{ V}$ , $I_D = 100\text{ mA}$	$ y_{fs} $	40	-	mS
Input Capacitance at $V_{DS} = 10\text{ V}$ , $f = 1\text{ MHz}$	$C_{iss}$	-	15	pF
Output Capacitance at $V_{DS} = 10\text{ V}$ , $f = 1\text{ MHz}$	$C_{oss}$	-	15	pF
Reverse Transfer Capacitance at $V_{DS} = 10\text{ V}$ , $f = 1\text{ MHz}$	$C_{rss}$	-	5	pF
Turn-On Time at $V_{GS} = 0\text{ to }10\text{ V}$ , $V_{DD} = 20\text{ V}$ , $I_D = 100\text{ mA}$	$t_{(on)}$	-	5	ns
Turn-Off Time at $V_{GS} = 10\text{ to }0\text{ V}$ , $V_{DD} = 20\text{ V}$ , $I_D = 100\text{ mA}$	$t_{(off)}$	-	10	ns

## PACKAGE OUTLINE

Plastic surface mounted package; 3 leads

SOT-23

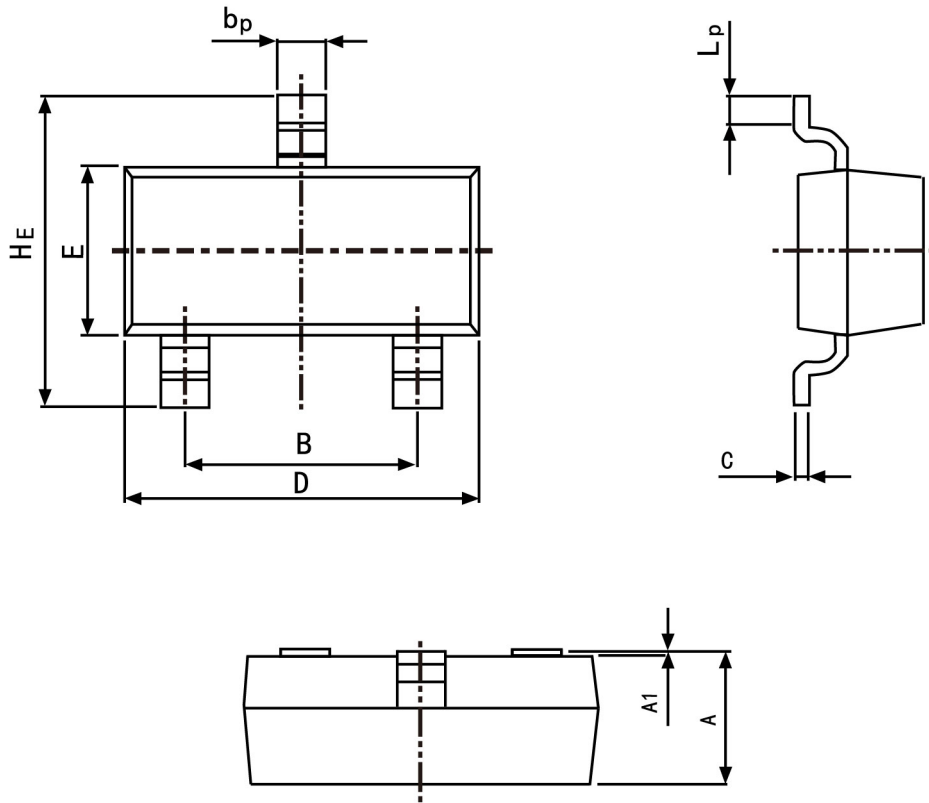

Symbol	Dimension in Millimeters	
	Min	Max
A	0.95	1.40
B	1.78	2.04
bp	0.35	0.50
C	0.08	0.19
D	2.70	3.10
E	1.20	1.65
HE	2.20	3.00
A1	0.100	0.013
Lp	0.20	0.50