

Plastic-Encapsulate MOSFETS

P-CHANNEL ENHANCEMENT MODE MOSFET

Features

- Low On-Resistance
- Low Gate Threshold Voltage
- Low Input Capacitance
- Fast Switching Speed
- Low Input/Output Leakage
- **Lead Free By Design/RoHS Compliant (Note 2)**
- **ESD Protected Up To 2kV**

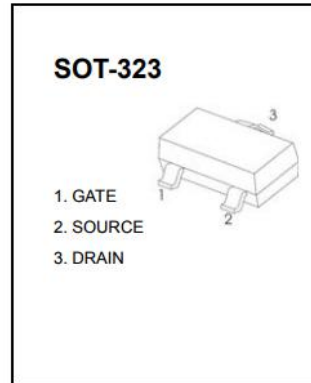
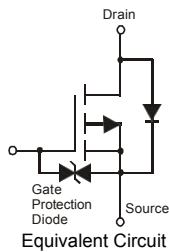

Marking Code: PA1

Maximum Ratings @ $T_A = 25^\circ\text{C}$ unless otherwise specified

Characteristic			Symbol	Value	Units
Drain-Source Voltage			V_{DSS}	-20	V
Gate-Source Voltage			V_{GSS}	± 6	V
Drain Current (Note 1)	Steady State	$T_A = 25^\circ\text{C}$	I_D	-0.46	A
		$T_A = 85^\circ\text{C}$		-0.33	
Pulsed Drain Current			I_{DM}	-6	A

Thermal Characteristics @ $T_A = 25^\circ\text{C}$ unless otherwise specified

Characteristic	Symbol	Value	Units
Total Power Dissipation (Note 1)	P_D	0.27	W
Thermal Resistance, Junction to Ambient	$R_{\theta JA}$	461	$^\circ\text{C}/\text{W}$
Operating and Storage Temperature Range	T_J, T_{STG}	-55 to +150	$^\circ\text{C}$

Notes: 1. Device mounted on FR-4 PCB.
2. No purposefully added lead.

Electrical Characteristics @ $T_A = 25^\circ\text{C}$ unless otherwise specified

Characteristic	Symbol	Min	Typ	Max	Unit	Test Condition
OFF CHARACTERISTICS (Note 4)						
Drain-Source Breakdown Voltage	BV_{DSS}	-20	-	-	V	$V_{GS} = 0V, I_D = -250\mu A$
Zero Gate Voltage Drain Current $T_J = 25^\circ\text{C}$	I_{DSS}	-	-	-100	nA	$V_{DS} = -20V, V_{GS} = 0V$
Gate-Source Leakage	I_{GSS}	-	-	± 2.0	μA	$V_{GS} = \pm 4.5V, V_{DS} = 0V$
ON CHARACTERISTICS (Note 4)						
Gate Threshold Voltage	$V_{GS(th)}$	-0.5	-	-1.0	V	$V_{DS} = V_{GS}, I_D = -250\mu A$
Static Drain-Source On-Resistance	$R_{DS(on)}$	-	0.5	0.7	Ω	$V_{GS} = -4.5V, I_D = -350mA$
			0.7	0.9		
			1.0	1.3		
Forward Transfer Admittance	$ Y_{fs} $	-	0.9	-	S	$V_{DS} = -10V, I_D = -250mA$
Diode Forward Voltage (Note 4)	V_{SD}	-	-0.8	-1.2	V	$V_{GS} = 0V, I_S = -150mA$
DYNAMIC CHARACTERISTICS						
Input Capacitance	C_{iss}	-	59.76	-	pF	$V_{DS} = -16V, V_{GS} = 0V,$ $f = 1.0MHz$
Output Capacitance	C_{oss}	-	12.07	-	pF	
Reverse Transfer Capacitance	C_{rss}	-	6.36	-	pF	
Total Gate Charge	Q_g	-	622.4	-	pC	$V_{GS} = -4.5V, V_{DS} = -10V,$ $I_D = -250mA$
Gate-Source Charge	Q_{gs}	-	100.3	-	pC	
Gate-Drain Charge	Q_{gd}	-	132.2	-	pC	
Turn-On Delay Time	$t_{D(on)}$	-	5.1	-	ns	$V_{DD} = -10V, V_{GS} = -4.5V,$ $R_L = 47\Omega, R_G = 10\Omega,$ $I_D = -200mA$
Turn-On Rise Time	t_r	-	8.1	-	ns	
Turn-Off Delay Time	$t_{D(off)}$	-	28.4	-	ns	
Turn-Off Fall Time	t_f	-	20.7	-	ns	

Notes: 4. Short duration pulse test used to minimize self-heating effect.

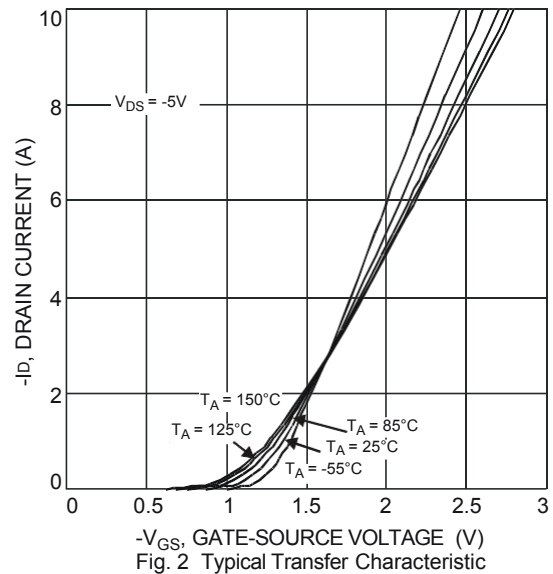
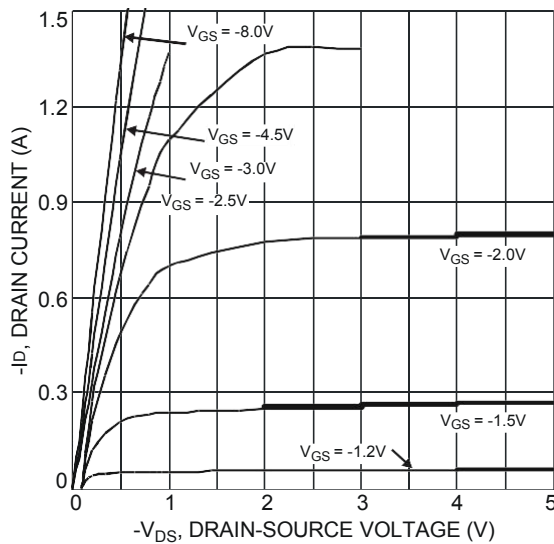

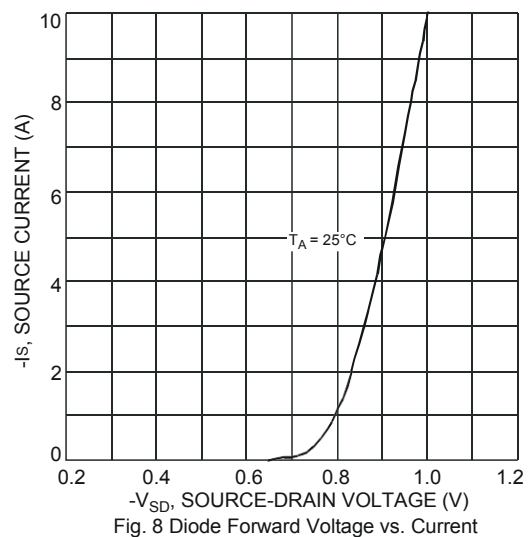
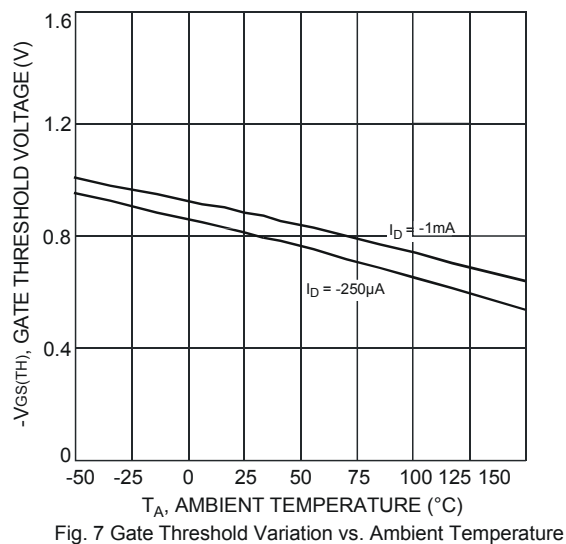
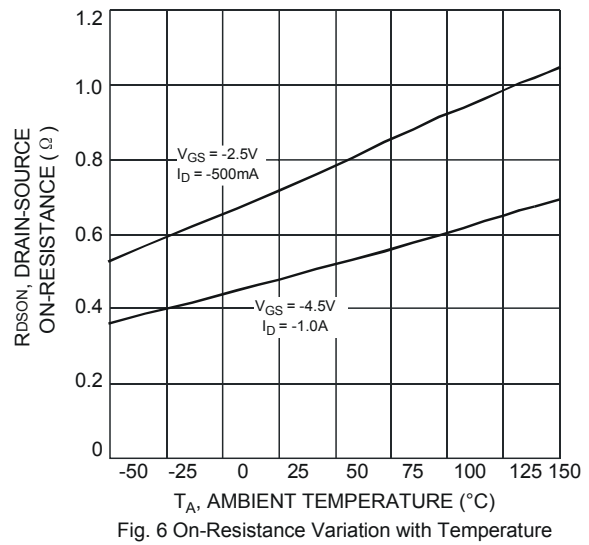
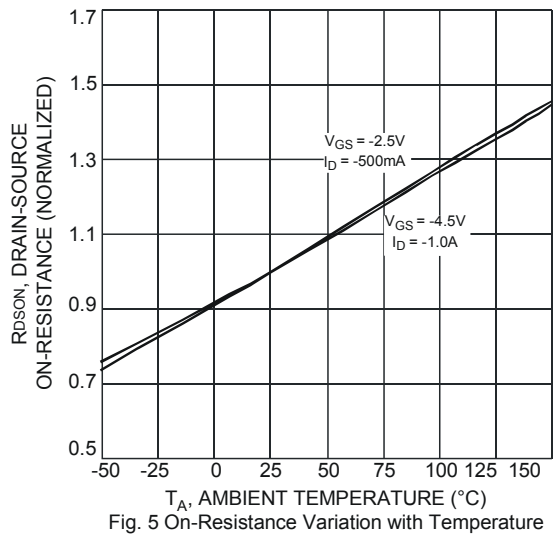
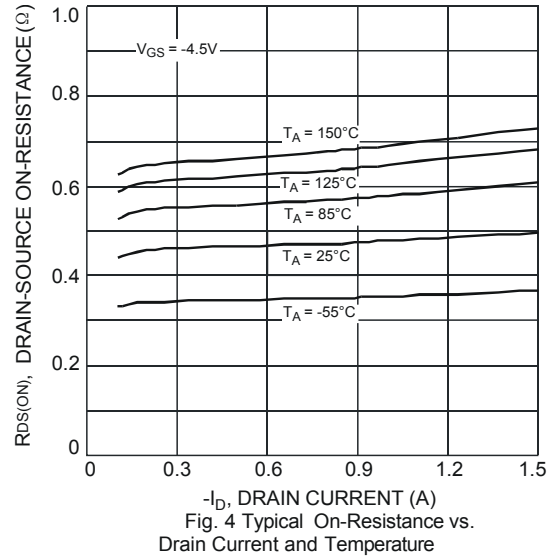
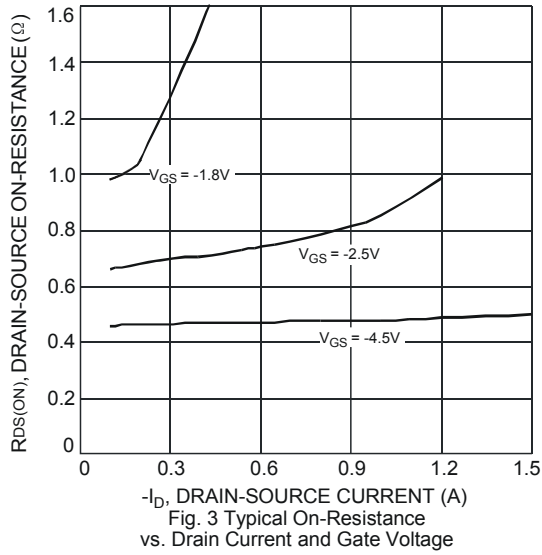



CHINA BASE
INTERNATIONAL

SOT-323

BC1013W



www.china-base.com.hk

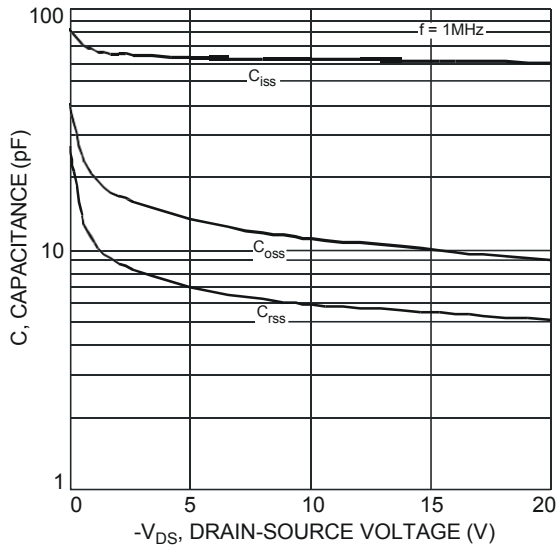

Fig. 9 Typical Total Capacitance

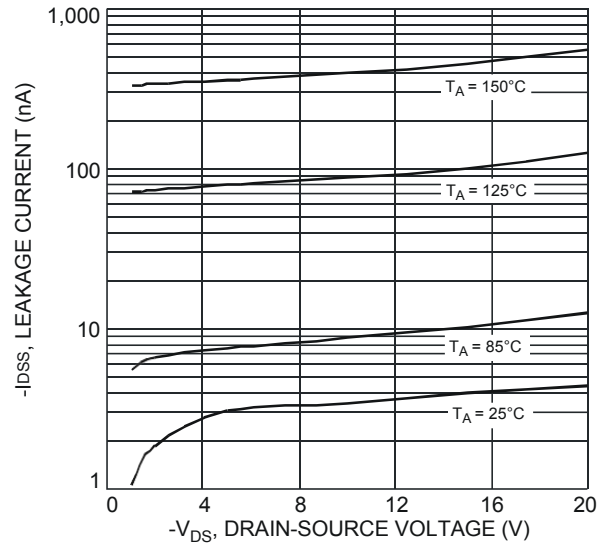

Fig. 10 Typical Leakage Current vs. Drain-Source Voltage

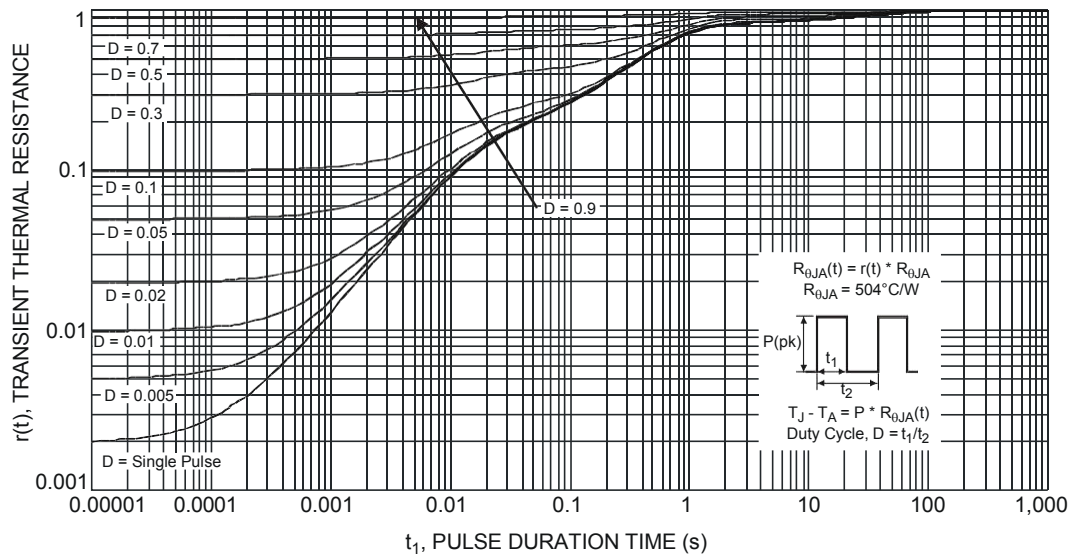

Fig. 11 Transient Thermal Response



PACKAGE OUTLINE

Plastic surface mounted package; 3 leads

SOT-323

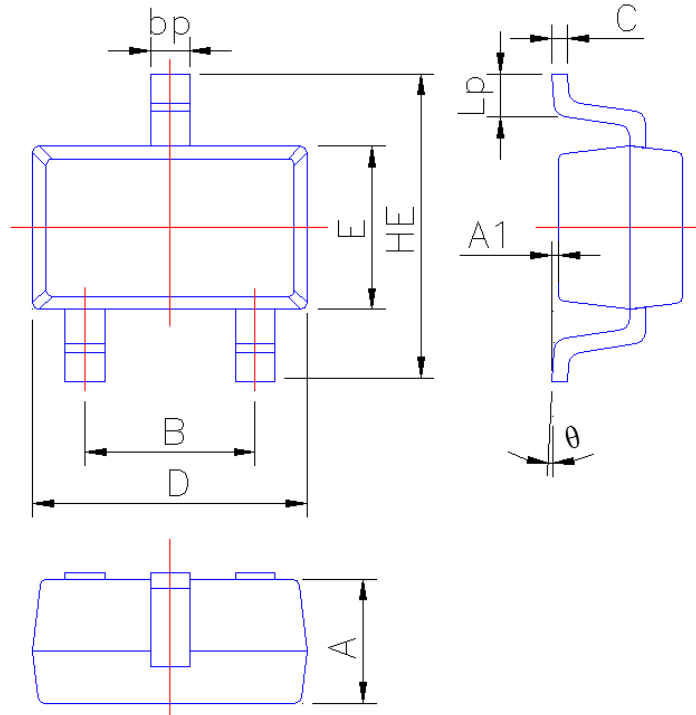

Symbol	Dimension in Millimeters	
	Min	Max
A	0.90	1.00
A1	0.010	0.100
B	1.20	1.40
bp	0.25	0.45
C	0.09	0.15
D	2.00	2.20
E	1.15	1.35
HE	2.15	2.55
Lp	0.25	0.46
θ	0°	6°